

CONTROL LINE VALVES

Control Line Valves – Dollies & Turnable Axles

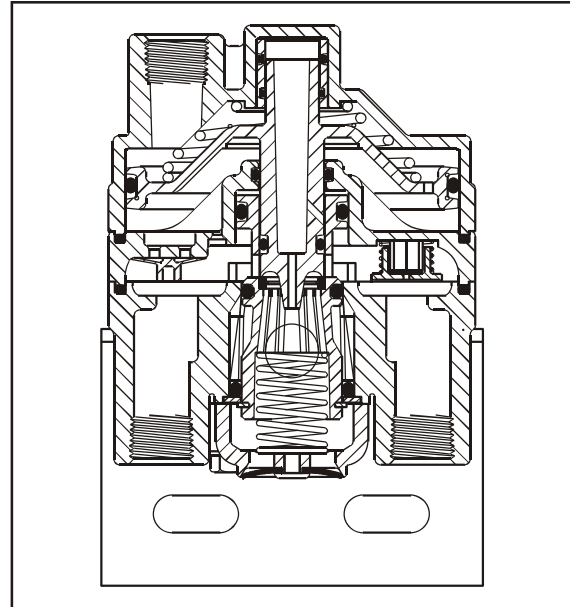
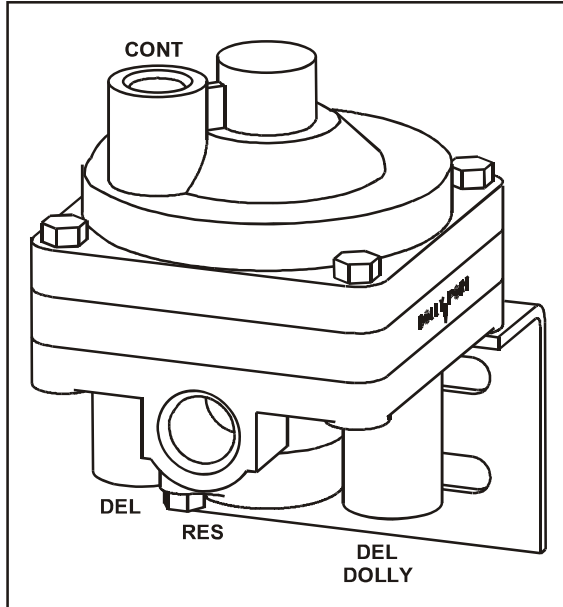

INFORMATION:

- Complies with all changes to FMVSS 121, Docket 85-07, Notice 7
- Primarily used on dollies & turnable axles on pull, transfer & B-train type trailers
- The dolly port of the Control Line valve is plumbed to the Relay Emergency Valve or ABS ECU to control the service brakes
- Provides a balanced control line signal for uniform braking of multi-axle combination vehicles
- Prevents premature braking of the steerable axle(s) in combination vehicles for maximum lateral stability while stopping.
- Improves the release of service brakes in the tractor/trailer combination eliminating trailer brake drag complaints
- Mounting Hardware on pages 61 & 62
- Piping examples on page 73

PART NUMBER	PORT SIZES (NPT)				NOMINAL CRACK PRESSURE	COMMENTS
	Control	Reservoir	Dolly	Delivery		
110570	3/8"	1/2"	3/8"	3/8"	0.0 psi	Includes Bracket as shown
110571	3/8"	1/2"	3/8"	3/8"	0.0 psi	Includes Bracket reversed
110690	3/8"	1/2"	3/8"	3/8"	0.0 psi	110570 without Bracket
110606	3/8"	1/2"	3/8"	3/8"	0.0 psi	110690 w/ 10200 1/2 Check Valve